

For Carbide, Cermet and HSS tool shanks with tolerance h6

Rev. 12-1101 Page 1 of 3  
Uncontrolled Document

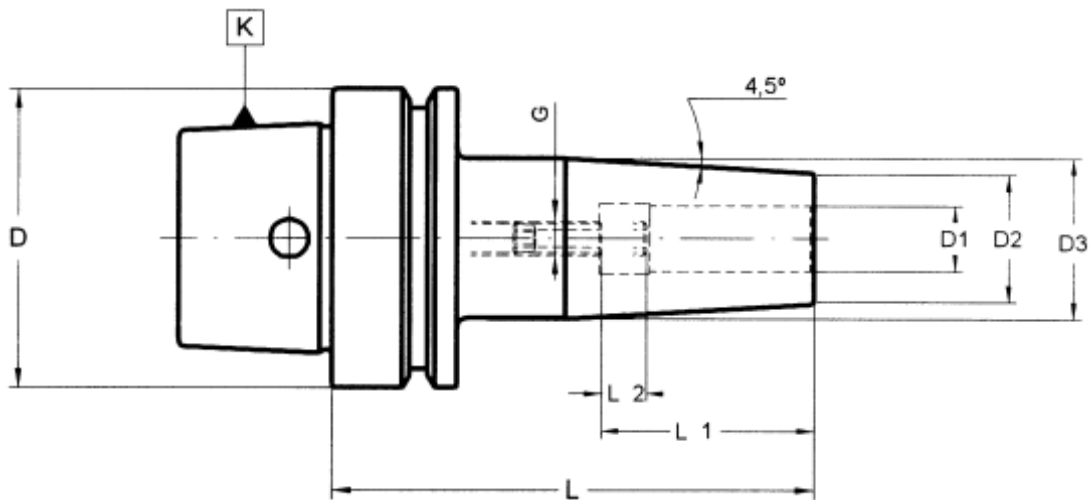

- Maximum circular deviation between K and D1  $\leq 0.003$  mm.
- For D1 = 6, tool shank tolerance h6.
- For D1 < 6, tool shank tolerance h4.
- For Carbide, Cermet and HSS tool shanks according to DIN 6535 form HA and DIN 1835-1 form A.
- Balanced according to ISO 1940-1 up to 15,000 rpm.
- We have latest methods for dynamic balancing up to 50,000 rpm.
- With build-in bored through stop screw.
- Other sizes and profiles on request.
- Coolant tube to be ordered separately.

Taper (D)	Length (L)	D1	Part Number
HSK-E 25	60	3	<a href="#">681.01218121003</a>
HSK-E 25	60	4	<a href="#">681.01218121004</a>
HSK-E 25	60	5	<a href="#">681.01218121005</a>
HSK-E 25	70	8	<a href="#">681.01218121008</a>
HSK-E 25	70	10	<a href="#">681.01218121010</a>
HSK-E 32	60	3	<a href="#">681.01218121103</a>
HSK-E 32	60	4	<a href="#">681.01218121104</a>
HSK-E 32	60	5	<a href="#">681.01218121105</a>
HSK-E 32	70	6	<a href="#">681.01218121106</a>
HSK-E 32	70	8	<a href="#">681.01218121108</a>
HSK-E 32	70	10	<a href="#">681.01218121110</a>
HSK-E 32	80	12	<a href="#">681.01218121112</a>
HSK-E 40	80	6	<a href="#">681.01218121206</a>

For Carbide, Cermet and HSS tool shanks with tolerance h6

Rev. 12-1101 Page 2 of 3  
Uncontrolled Document



Taper (D)	Length (L)	D1	Part Number
HSK-E 40	80	8	681.01218121208
HSK-E 40	80	10	681.01218121210
HSK-E 40	90	12	681.01218121212
HSK-E 40	90	14	681.01218121214
HSK-E 40	90	16	681.01218121216
HSK-E 50	80	6	681.01218121306
HSK-E 50	80	8	681.01218121308
HSK-E 50	85	10	681.01218121310
HSK-E 50	90	12	681.01218121312
HSK-E 50	90	14	681.01218121314
HSK-E 50	95	16	681.01218121316
HSK-E 50	95	18	681.01218121318
HSK-E 50	100	20	681.01218121320
HSK-E 63	80	3	681.01218121403
HSK-E 63	80	4	681.01218121404
HSK-E 63	80	5	681.01218121405
HSK-E 63	80	6	681.01218121406
HSK-E 63	80	8	681.01218121408
HSK-E 63	85	10	681.01218121410
HSK-E 63	90	12	681.01218121412
HSK-E 63	90	14	681.01218121414
HSK-E 63	95	16	681.01218121416
HSK-E 63	95	18	681.01218121418
HSK-E 63	100	20	681.01218121420
HSK-E 40	120	3	681.01218122203
HSK-E 40	120	4	681.01218122204
HSK-E 40	120	5	681.01218122205
HSK-E 40	120	6	681.01218122206
HSK-E 40	120	8	681.01218122208
HSK-E 40	120	10	681.01218122210
HSK-E 40	120	12	681.01218122212
HSK-E 50	120	3	681.01218122303
HSK-E 50	120	4	681.01218122304
HSK-E 50	120	5	681.01218122305
HSK-E 50	120	6	681.01218122306
HSK-E 50	120	8	681.01218122308

For Carbide, Cermet and HSS tool shanks with tolerance h6

Rev. 12-1101 Page 3 of 3  
Uncontrolled Document



Taper (D)	Length (L)	D1	Part Number
HSK-E 50	120	10	681.01218122310
HSK-E 50	120	12	681.01218122312
HSK-E 63	120	3	681.01218122403
HSK-E 63	120	4	681.01218122404
HSK-E 63	120	5	681.01218122405
HSK-E 63	120	6	681.01218122406
HSK-E 63	120	8	681.01218122408
HSK-E 63	120	10	681.01218122410
HSK-E 63	120	12	681.01218122412
HSK-E 63	120	14	681.01218122414
HSK-E 63	120	16	681.01218122416
HSK-E 63	160	6	681.01218123406
HSK-E 63	160	8	681.01218123408
HSK-E 63	160	10	681.01218123410
HSK-E 63	160	12	681.01218123412
HSK-E 63	160	14	681.01218123414
HSK-E 63	160	16	681.01218123416

Available for HSK-E 25, 32, 40, 50, 63. Other dimensions available on request.

## TAC Rockford Product Line

Machine Tool Gauges, Tool Changer Alignment, Runout Test Arbors, Workholding Systems, Tool Holders, Adapters and Extensions, Tool Holder Blanks, Machine Tool Accessories, Coolant Tubes and Gauges, Heat Shrink Systems, Rapid Prototyping

### Tool Holders

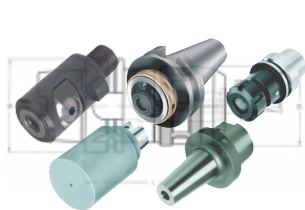

### Gauges



### Accessories

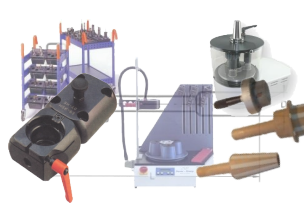

### Rapid Prototyping

