

For end mills with shank DIN 1835-B and / or DIN 1835-E

Rev. 12-1101 Page 1 of 2
Uncontrolled Document

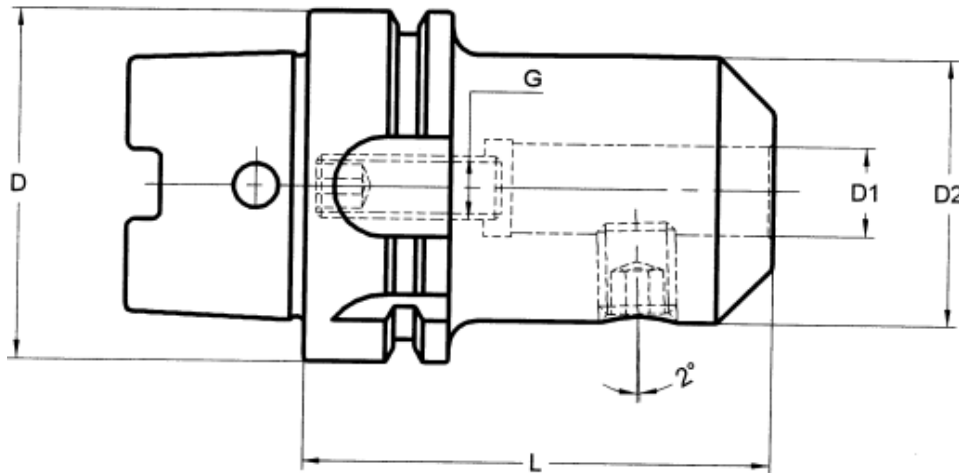

DIN 69882-5

- The hole diameter and circular deviation tolerances have been significantly tightened up compared with DIN 1835 in order to achieve the highest levels of machining precision.
- Coolant tube to be ordered separately.
- Balanced according to ISO 1940-1 up to 10,000 rpm. We have the latest methods for dynamic balancing up to 50,000 rpm.
- D1 <= 25 mm: two clamping holes.
- Maximum circular deviation between outer taper and D1 <= 0.003 mm.

Taper (D)	Length (L)	D1	D2	G	Part Number
HSK-A 32	80	6	25	M-5	681.01214021106
HSK-A 32	80	8	28	M-6	681.01214021108
HSK-A 32	80	10	35	M-8	681.01214021110
HSK-A 40	80	6	25	M-5	681.01214021206
HSK-A 40	80	8	28	M-6	681.01214021208
HSK-A 40	90	10	35	M-8	681.01214021210
HSK-A 40	95	12	42	M-10	681.01214021212
HSK-A 40	95	14	44	M-10	681.01214021214
HSK-A 40	95	16	48	M-12	681.01214021216
HSK-A 50	80	6	25	M-5	681.01214021306
HSK-A 50	80	8	28	M-6	681.01214021308
HSK-A 50	80	10	35	M-8	681.01214021310
HSK-A 50	90	12	42	M-10	681.01214021312
HSK-A 50	90	14	44	M-10	681.01214021314
HSK-A 50	90	16	48	M-12	681.01214021316
HSK-A 50	90	18	50	M-12	681.01214021318
HSK-A 50	100	20	52	M-16	681.01214021320
HSK-A 63	80	6	25	M-5	681.01214021406
HSK-A 63	80	8	28	M-6	681.01214021408

For end mills with shank DIN 1835-B and / or DIN 1835-E

Rev. 12-1101 Page 2 of 2
Uncontrolled Document



Taper (D)	Length (L)	D1	D2	G	Part Number
HSK-A 63	80	10	35	M-8	681.01214021410
HSK-A 63	90	12	42	M-10	681.01214021412
HSK-A 63	90	14	44	M-10	681.01214021414
HSK-A 63	100	16	48	M-12	681.01214021416
HSK-A 63	100	18	50	M-12	681.01214021418
HSK-A 63	100	20	52	M-16	681.01214021420
HSK-A 63	110	25	65	M-20	681.01214021425
HSK-A 63	110	32	72	M-20	681.01214021432
HSK-A 80	90	6	25	M-5	681.01214021506
HSK-A 80	100	12	42	M-10	681.01214021512
HSK-A 80	100	14	44	M-10	681.01214021514
HSK-A 80	100	16	48	M-12	681.01214021516
HSK-A 80	100	18	50	M-12	681.01214021518
HSK-A 80	110	25	52	M-16	681.01214021525
HSK-A 100	90	6	25	M-5	681.01214021606
HSK-A 100	90	8	28	M-6	681.01214021608
HSK-A 100	90	10	35	M-8	681.01214021610
HSK-A 100	100	12	42	M-10	681.01214021612
HSK-A 100	100	14	44	M-10	681.01214021614
HSK-A 100	100	16	48	M-12	681.01214021616
HSK-A 100	100	18	50	M-12	681.01214021618
HSK-A 100	110	20	52	M-16	681.01214021620
HSK-A 100	120	25	65	M-20	681.01214021625
HSK-A 100	120	32	72	M-20	681.01214021632

Available for HSK-A 32, 40, 50, 63, 80, 100

TAC Rockford Product Line

Machine Tool Gauges, Tool Changer Alignment, Runout Test Arbors, Workholding Systems, Tool Holders, Adapters and Extensions, Tool Holder Blanks, Machine Tool Accessories, Coolant Tubes and Gauges, Heat Shrink Systems, Rapid Prototyping

Tool Holders



Gauges



Accessories

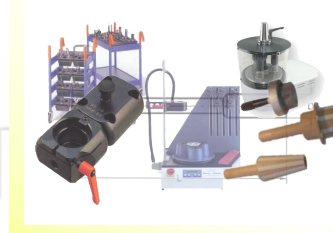

Rapid Prototyping

