

HSK 25/32

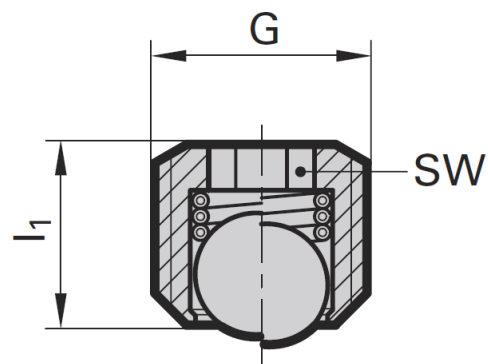

HSK 40 -100



For brass locking rings. Minimum order quantity of 5.

Taper	Length (l1)	G	SW	Part Number
HSK 25	3.4	M3.5	2.0	683.4961.003.500
HSK 32	4.3	M4	2.0	683.4961.004.000
HSK 32	4.0	M4	2.0	683.4961.004.001
HSK 40	4.6	M5	2.5	683.4961.005.000
HSK 50	5.4	M6	3.0	683.4961.006.000
HSK 63	7.0	M8	4.0	683.4961.008.000
HSK 80	9.2	M10	5.0	683.4961.010.000
HSK 100	11.4	M12	6.0	683.4961.012.000

TAC Rockford Product Line

Machine Tool Gauges, Tool Changer Alignment, Runout Test Arbors, Workholding Systems, Tool Holders, Adapters and Extensions, Tool Holder Blanks, Machine Tool Accessories, Coolant Tubes and Gauges, Heat Shrink Systems, Rapid Prototyping

Tool Holders



Gauges



Accessories

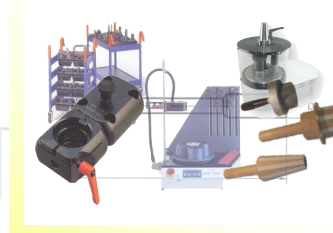

Rapid Prototyping

