

SSKE

Spannsatz  
Gripper

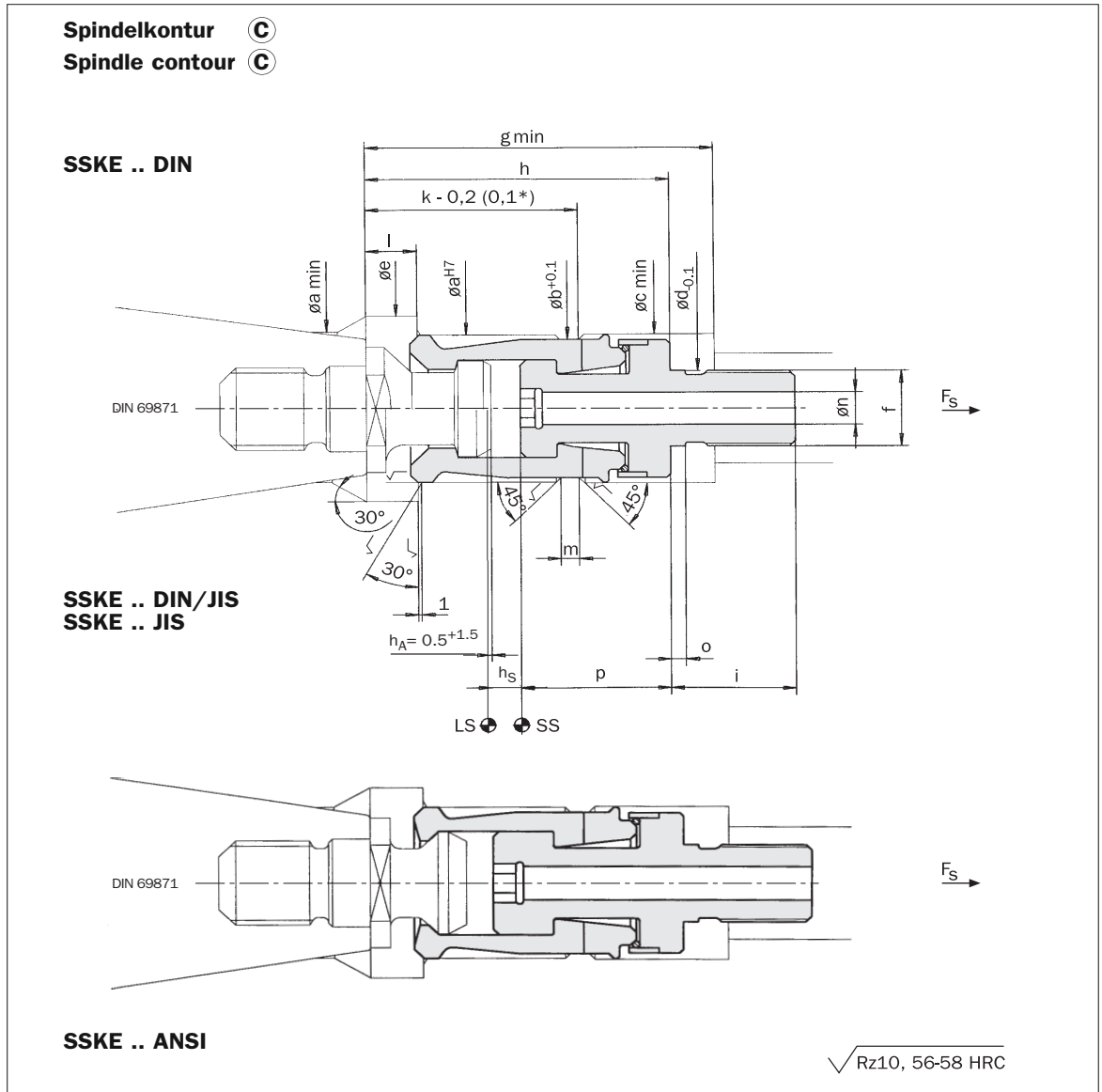

Maße | Technische Daten  
Dimensions | Technical Data

Typ Type	a	b	c	d	e	f	g	h	i	k	l	m	n	o	p	h <sub>S</sub>	F <sub>S max</sub> kN	SW mm	M <sub>A</sub> Nm
SSKE 30DIN*	19	17,8	20,2	10	24	M 10	50	47	20	37	7,5	3,5	3,0	3	19,5	4,0	10	6	30
SSKE 30JIS*	19	17,8	20,2	10	24	M 10	50	47	20	37	7,5	3,5	3,0	3	20,1	4,0	10	6	30
SSKE 30ANSI*	19	17,8	19,5	10	24	M 10	50	47	20	37	7,5	3,5	3,0	3	33,0	3,0	10	6	30
SSKE 35JIS	23	21,4	23,5	12	29	M 12 x 1,5	58	55	20	42,5	9	4,0	5,0	3	27,0	4,5	12	6	30
SSKE 40DIN	28	26,4	28,5	16	35	M 16 x 1,5	82	70	26	52	10	4,5	7,0	4	39,0	5,5	18	8	65
SSKE 40JIS	28	26,4	28,5	16	35	M 16 x 1,5	82	70	26	52	10	4,5	7,0	4	36,5	5,0	18	8	65
SSKE 40ANSI	28	26,4	28,5	16	35	M 16 x 1,5	82	70	26	52	10	4,5	7,0	4	50,0	4,5	18	8	65
SSKE 45DIN/JIS	36	34,0	36,5	18	45	M 18 x 1,5	89	80	32	60	13	4,5	8,0	4	43,0	7,5	25	8	110
SSKE 45ANSI	36	34,0	36,5	18	45	M 18 x 1,5	89	80	32	60	13	4,5	8,0	4	53,0	6,5	25	8	110
SSKE 50DIN/JIS	43	40,4	43,5	22	54	M 22 x 1,5	98	90	35	69	16	5,0	9,5	5	48,0	8,5	35	10	160
SSKE 50ANSI	43	40,4	43,5	22	54	M 22 x 1,5	98	90	35	69	16	5,0	9,5	5	58,0	7,0	35	10	160
SSKE 55JIS	55	52,4	55,5	30	67	M 30 x 1,5	113	105	40	80	20	5,0	16,0	5	48,0	9,5	50	17	320
SSKE 60DIN	62	58,6	62,5	30	77	M 30 x 1,5	130	125	40	96	23	6,5	16,0	5	74,5	11,0	70	17	470
SSKE 60JIS	62	58,6	62,5	30	77	M 30 x 1,5	130	125	40	96	23	6,5	16,0	5	66,5	11,0	70	17	470

SSKE

Spannsatz  
Gripper

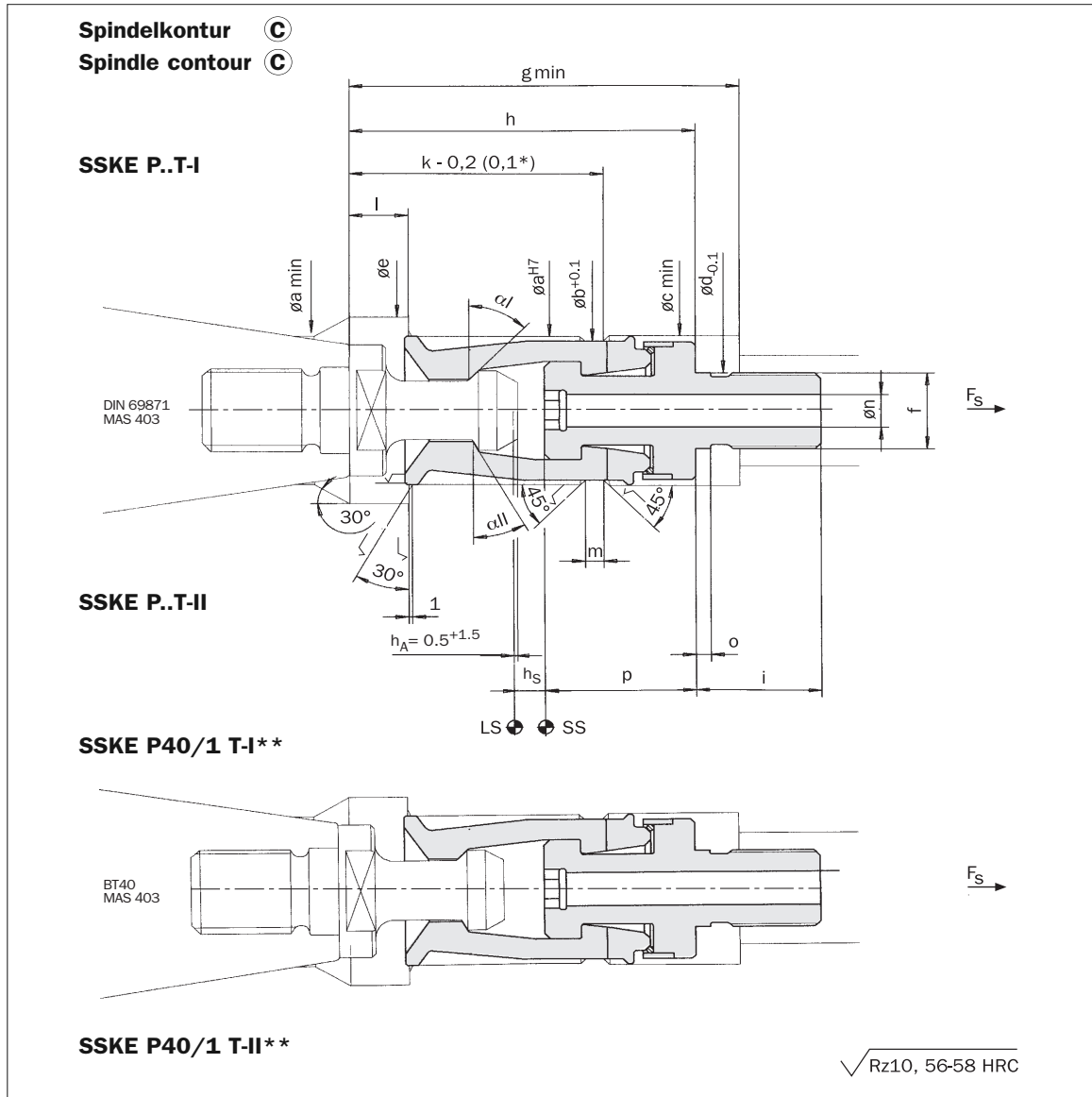

Maße | Technische Daten  
Dimensions | Technical Data

Typ Type	$\alpha$ $\pm 15'$	a	b	c	d	e	f	$g_{min}$	h	i	k	l	m	n	o	p	$h_s$	$F_s$ max kN	SW mm	$M_A$ Nm
SSKE P30T-I*	45°	19	17,8	20,2	10	24	M 10	50	47	20	37,0	7,5	3,5	3	3	20,5	4,0	10	6	30
SSKE P30T-II*	30°	19	17,8	20,2	10	24	M 10	50	47	20	37,0	7,5	3,5	3	3	20,5	4,0	10	6	30
SSKE P35T-I	45°	23	21,4	23,5	12	29	M 12 x 1,5	58	55	20	42,5	9,0	4,0	5	3	23,0	4,5	12	6	30
SSKE P35T-II	30°	23	21,4	23,5	12	29	M 12 x 1,5	58	55	20	42,5	9,0	4,0	5	3	23,0	4,5	12	6	30
SSKE P40T-I	45°	28	26,4	28,5	16	35	M 16 x 1,5	82	70	26	52,0	10,0	4,5	6	4	30,0	5,5	18	6	65
SSKE P40/1T-I**	45°	28	26,4	28,5	16	35	M 16 x 1,5	82	70	26	52,0	10,0	4,5	6	4	33,0	5,5	18	6	65
SSKE P40T-II	30°	28	26,4	28,5	16	35	M 16 x 1,5	82	70	26	52,0	10,0	4,5	6	4	30,0	5,5	18	6	65
SSKE P40/1T-II**	30°	28	26,4	28,5	16	35	M 16 x 1,5	82	70	26	52,0	10,0	4,5	6	4	33,0	5,5	18	6	65
SSKE P45T-I	45°	36	34,0	36,5	18	45	M 18 x 1,5	89	80	32	60,0	13,0	4,5	8	4	33,0	7,5	25	8	110
SSKE P45T-II	30°	36	34,0	36,5	18	45	M 18 x 1,5	89	80	32	60,0	13,0	4,5	8	4	33,0	7,5	25	8	110
SSKE P50T-I	45°	43	40,4	43,5	22	54	M 22 x 1,5	98	90	35	69,0	16,0	5,0	9,5	5	37,0	8,5	35	10	160
SSKE P50T-II	30°	43	40,4	43,5	22	54	M 22 x 1,5	98	90	35	69,0	16,0	5,0	9,5	5	37,0	8,5	35	10	160
SSKE P60T-I	45°	62	58,6	62,5	30	77	M 30 x 1,5	130	125	40	96,0	23,0	6,5	16	5	49,5	11,0	70	17	450
SSKE P60T-II	30°	62	58,6	62,5	30	77	M 30 x 1,5	130	125	40	96,0	23,0	6,5	16	5	49,5	11,0	70	17	450